



## Experimental evaluation of transient heat transfer performance of an automotive condenser designed for R744 refrigerant

Sasan Zanganeh, Mohammad Hassan Shojaeefard,\* Gholam Reza Molaeimanesh, Masoud Dahmardeh, and Mahdi Mohammadi Aghdash

1\* School of Automotive Engineering, Iran University of Science and Technology, Tehran

### ARTICLE INFO

#### Article history:

Received : 2 Sep 2022

Accepted: 18 Nov 2022

Published: 27 Dec 2022

#### Keywords:

Automotive

Condenser

R744

HVAC

high pressure

wind tunnel

### ABSTRACT

As alternatives for future refrigeration, heat pumping, air conditioning, or even power generation plants are emerging due to the regulatory changes, R744 (carbon dioxide) is considered as a serious alternative to be the successor of other Halogenated Hydrocarbons Refrigerants (HHR) for the AC-system of vehicles. This paper investigates the heat transfer performance of R744 through a subcritical vehicular condenser, designed and manufactured for the first product based on NP01 platform (Iranian vehicle), at different operating conditions in terms of refrigerant mass flow rate and wind velocity. The experiments carried out in order to investigate the effect of mass flow rate, the R744 inlet temperature was observed to have sudden fluctuations. At the condenser outlet, for the smallest mass flow rate, the least variation of temperature was observed. It was also found out that for higher air velocities through the condenser, the stabilized temperature after the condenser was lower. The results show that the performance of the designed and manufactured automotive condenser based on R744 refrigerant is acceptable which makes it a suitable candidate for automotive applications.

## 1. Introduction

Heating, ventilation, and air conditioning (HVAC) system is a major source of energy consumption in vehicles [1]. Since its introduction, various refrigerants are utilized [2–7]. The most of refrigerants originally were halogen based chemical compounds or Halogenated Hydrocarbons Refrigerants (HHR) such as Hydrofluorocarbons (HFC) and Hydrochlorofluorocarbons (HCFCs). However, due to irreparable environmental harms of these refrigerant gases and in accordance to the concerning protection of global protocols like Montreal Protocol (1987) agreement, employment of these refrigerants was prohibited [14]. Regarding

this protocol in 2012, all of the industrialized countries must reduce their dense emissions of greenhouse gases 5% below the 1990 levels. In order to reduce the evacuation of ozone layer and invert the climate change factors, the European Union legislation (2014) and Paris Accord (2016) are strictly emphasizing the elimination of the utilization of detrimental and harmful synthetic refrigerant gases. Choosing natural refrigerants does not lead to the greenhouse gases (GHG) in the environment. To modify and alter existing HVAC systems using green refrigerants, further investigations are carried out worldwide. Manufacturers of HVAC

\*Corresponding Author

Email: [shojaeefard@iust.ac.ir](mailto:shojaeefard@iust.ac.ir)

<http://doi.org/10.22068/ase.2022.626>

## Experimental evaluation of transient heat transfer performance of an automotive condenser designed for R744 refrigerant

systems are trying to employ environmentally friendly refrigerants such as CO<sub>2</sub> (R744). R744 is environmentally friendly, with zero Ozone Depletion Potential (ODP) and minimum Global Warming Potential (GWP). The low energy consumption and good thermodynamic properties makes it a good candidate for a wide range of applications such as chilled warehousing, industrial heat extraction, shipping vessels, commercial refrigeration, and mobile air conditioning. Although R744 has been utilized in a wide range of industrial sector, however, the employment for vehicular applications was not successful yet. The main difference between R744 and other refrigerants is the pressure/temperature characteristics. Because of relatively high pressure of compression refrigeration cycles based on R744, special care should be taken when choosing the required equipment. Therefore, in order to meet these growing needs, R744 refrigeration cycles technologies are developed in recent years, especially in the factories at Carnot refrigeration. Even though R744 is a non-toxic and non-flammable gas which is extensively achievable, it is not appropriate for the vehicular HVAC systems, considering packaging and weight issues, which should be taken into account carefully. Therefore, in this emerging scope, more investigations are needed [1].

Several studies on R744 refrigeration cycles with general applications are conducted. Pitarch et al. [15] investigated the environmental effects of R744 and its effectiveness in air conditioning systems. Their test results show that the R744 system has an equivalent efficiency of 15% more than R134a system. Aprea et al. [16] compared the two R134a and R744 refrigerant systems and the experiments showed that the performance of carbon dioxide is 20% to 44% better than the one for R134a. Turgut and Turgut [17] analyzed and compared the performance of three cascade refrigeration systems operating with three

refrigerant pairs of R744/R1234yf, R744/R717, R744/R134a. They found out that for the R744/R1234yf pair, the highest 2nd law efficiency and the lowest operating cost can be achieved. Ge et al. [18] designed and optimized R744 refrigerant cooler/condenser of a refrigeration system. They investigated the effects of CO<sub>2</sub> gas cooler/condenser size and control on the system performance. Ding and Li [19] studied the heat transfer characteristics of super critical carbon dioxide (R744) inside horizontal tube and provided an experimental correlation. Boiling heat transfer characteristics of the R744 coolant is studied [20]. The heat transfer characteristics of the boiling heat transfer coefficient and flowing pattern inside the vapor tube is investigated. Linlin et al., on the other hand, investigated CO<sub>2</sub> flow characteristics of boiling heat transfer at low temperature in mini-channels [21]. Yoon et al. investigated experimentally the heat transfer features of R744 at low temperatures (between -20 °C and -30 °C) during evaporation in a horizontal smooth tube. Son and Oh investigated experimentally the heat transfer features of R744 during condensation by flowing in a horizontal microfin tube with respect to condensation temperature and mass flux, [22].

Only a few investigations about vehicular R744 HVAC systems have been conducted, so far. Brown et al. [23] presented a comparison between the performance of an automotive air conditioning system operating with R744 and R134a. The study indicated that R134a has a better COP, under the test conditions, compared with R744. Tamura and et al. [24] concentrated on a solution usage of R744 based heat pump as an alternative approach. Instead of using electric heaters, they utilized the wasted heat in the heat pump cycle during dehumidification of fresh inlet air as an auxiliary heat source.

To the best of authors' knowledge, the heat transfer performance of an automotive R744 condenser/gas cooler is not investigated

experimentally. In the current investigation, an automotive R744 condenser is designed, manufactured and experimentally tested in a wind tunnel. The heat transfer performance is analyzed for various transient operating conditions, in terms of refrigerant mass flow rate and wind velocity. In the following sections the experimental method and the results of experimental tests will be presented and discussed.

## 2. Experimental

### • Setup Assembly

As the first step of developing the automotive R744 refrigeration cycle project, a 61 cm \* 40 cm \* 4 cm one-pass parallel louvered-fin and tube condenser is designed and manufactured (Figure 1). The condenser is designed to be able for operating under pressures as high as 90 bar. Therefore, it can also act as a gas cooler in a transcritical R744 refrigeration cycle. Besides, considering the packaging issues its dimensions are selected in a way that it can be replaced by the current condenser in the first product based on NP01 platform (a sedan developed in Iran).

In order to evaluate the heat transfer performance of this condenser, an experimental setup is prepared and the R744 refrigerant tests are carried out in a wind tunnel at different wind velocities and mass flow rates. Figure 2 shows the schematic diagram of the equipment facility used for the CO<sub>2</sub> cooling performance test.

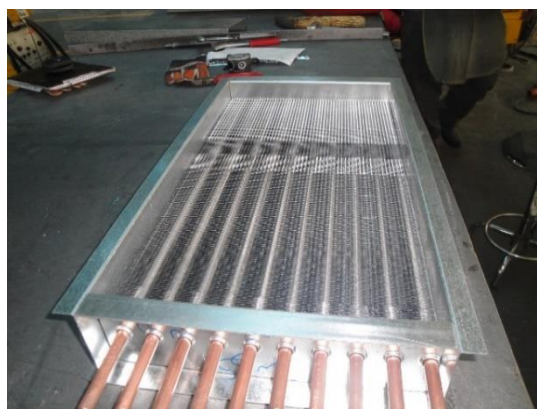

Figure 1: The designed and manufactured automotive condenser for high pressure R744 refrigeration cycle.

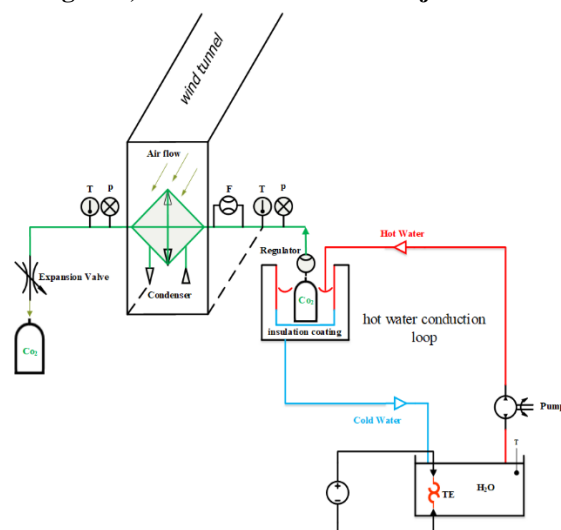

Figure 2: Schematic diagram of the equipment facility used for the CO<sub>2</sub> cooling performance test.

In order to supply the high pressure R744 gas for this condenser without the need for compressor and evaporator, an innovative setup consisting of two high pressure cylindrical vessels made of stainless steel is employed (Fig. 3). In this setup, one of the vessels (containing R744 at 60 bar) is the supplier of R744 while the other one (initially evacuated) is the receiver of the condenser outlet gas which also passes through an expansion valve after the condenser. The temperature of the high-pressure vessel can be controlled and stabilized via a water jacket designed for the high-pressure vessel. Therefore, the supply line pressure can be maintained at 60 bar.



Figure 3: The wind tunnel and the condenser testing apparatus.

A pressure regulator after the high-pressure vessel, three pressure gauges, four thermometers, hot wires and connecting tubes, are parts of the experimental setup. The capsules made of stainless steel without

## Experimental evaluation of transient heat transfer performance of an automotive condenser designed for R744 refrigerant

any leakage. The pressure regulator is HARIS type developed for high pressures. It is made of stainless steel with chromate coating and has the ability to control the output pressure in the range of 10 bar to 280 bar. Moreover, it is equipped with a relief valve. The connecting tubes used in this experiment are made of copper metal based on K65 alloy which can tolerate 120 bar pressure. This high stability alloy has an appropriate mechanical strength to respond to the high pressure of the CO<sub>2</sub>. The fittings are made of brass and with a high level of gas proof at high pressure. The tubes and the fittings are thermally insulated.

The flowmeter located between the supplier vessel and the condenser consists of two pressure gages for measuring the static pressure  $P_{stat}$  and stagnation pressure  $P_{stag}$ . By this way, the mass flow rate can be determined at any given time by:

$$\dot{m}_{R744} = \rho_{R744} A \left[ 2 * \frac{P_{stag} - P_{stat}}{\rho_{744}} \right]^{\frac{1}{2}} \quad (1)$$

where,  $A$  is the inner area of the tube cross section and  $\rho_{R744}$  is the R744 density, which can be determined by measuring the temperature via the ideal gas law.

The same as flowmeter, due to the high working pressure, two special thermometers were designed, constructed and installed on the high-pressure line, one before the condenser and the other after it. To meet this target, a three-way stainless steel cover and a special resin glue, as well as leather and drawing reels are used for placing and sealing the high pressure Lm35 sensor in the high pressure R744 line. The leather makes the connection seamless and drawing reels (fibers) will cause the pressure to be uniform. Its output is accurate to one hundredth of a decimal. One of the superiorities of this thermometer is the ability of upgrading up to 200 bar pressure. The expansion valve is a

relief valve which is used for changing the refrigerant exiting mass flow rate.

The hot water circuit for stabilizing the temperature of the supplier vessel via a constant temperature jacket was used. In addition to the water jacket, the water circuit consists of an insulated water tank, a thermocouple, a water pump, water conducting pipes, power cables, and a set of rod stoves. The rod stoves were used to raise the temperature of water tank to the desired point of 44.0 °C. When the jacket temperature tends to fall below 22.0 °C (the saturation temperature of R744 at 60 bar), the water pump transfers the hot water from the water tank to the jacket to keep the jacket temperature (and consequently, the high-pressure vessel) stabilized at 22.0 °C. On the other hand, when the jacket temperature tends to rise above 22.0 °C, the cold fresh water with about 10 °C temperature enters the jacket. The jacket is equipped by a relief valve to drain the excess water, if necessary. To control and keep the water temperature and stove temperature stable, a TP 100 thermocouple is employed. In addition, a controller was used (R14Y-4Autonics TC). Using this controller and sensor, the temperature of the water used to stabilize the R744 temperature inside the cylindrical vessel was controlled with high precision. In order to measure the air velocity in the wind tunnel (before and after the condenser) hot wires are used; These sensors are precise measuring devices for analyzing temperature, velocity, and discharge, as well as for

Table 1: The uncertainty of employed measuring devices.

Measuring tool	Operating range	Uncertainty
Hot wires	0.1-30 m/s	±3%
Water circuit thermocouple	-50 to +1100 °C	0.1 °C
Refrigerant circuit thermometers	-50 to +1100 °C	0.1 °C
Pressure gauges	0-100 bar	2 bar

studying the environmental conditions of a condenser in a wind tunnel. In this test, the TES-1341 cfm Hot-Wire Anemometer was used. Which is the most accurate type of hot-wire that equipped to data logger which has

### 3. Calibration

In order to calibrate the high-pressure gauges and ensure the sufficient accuracy of pressure measurements during falling or rising of pressure, NACI lab equipment is adopted (Certificate No. 197) which includes: 1- Pressure calibrator/ S.N. 61015223, 2- Pressure comparator/ S.N. 535, 3- Pressure test gauge/ S.N. 1030247.

The temperature sensors are calibrated using a large enough container of stable and controllable source of temperature. The sensor is completely immersed in the container and the calibration process is carried out using FLUKE and the resistance is measured from 0 to 100 °C in a step of 5 °C. The hot-wire anemometers are calibrated in the wind tunnel and tuning the coefficients of the hot-wires.

### 4. Test Procedures

Several transient tests in different operating conditions in terms of wind velocity and R744 mass flow rate were performed and the refrigerant temperatures at the inlet and the outlet of the condenser as well as the air temperatures before and after the condenser heat exchanger are logged. In all experiments, the temperature of the supply vessel is controlled to be stabilized at 22.0 °C. In addition to using a pressure regulator, this temperature controlling is performed to ensure that the supply pressure of the condenser is 60 bar. The mass flow rate of R744 through the condenser is regulated via the expansion valve (EXV) while the air velocity through the condenser is regulated by changing the frequency of electric power supply for the wind tunnel electric motor. The temperature of the air crossing the condenser in all experiments was near 10 °C. In order to ensure that the condenser outlet contain no CO<sub>2</sub> gas (i.e., it is completely liquefied), only the results of the tests are documented and reported in which the outlet temperature of

the condenser be below 21.9 °C. In all experiments conducted to evaluate the condenser performance during the startup process of vehicle HVAC system, the initial temperature of the condenser and its connections equals environment temperature (10 °C). At the starting time, the expansion valve is opened at a specified amount while the wind tunnel is also started with a specified electric motor rotational velocity. Therefore, the refrigeration mass flow rate and the air velocity quickly become steady while the temperatures of the refrigerant and air experience the transient behavior. Two groups of experiments have been conducted in this study. In the first group, the air velocity through the cross flow condenser is constant and the R744 mass flow rate is varied while in the second group, the R744 mass flow rate is constant and the air velocity is varied. The results of these two groups of experiments are presented in the next section.

## 5. Results and Discussion

### 5.1. Effects of refrigerant mass flow rate

In the first group of experiments, the air velocity on the center line of wind tunnel was fixed at 5 m/s. Besides, the inlet pressure of the R744 refrigerant was fixed on 60 bar via controlling the supply vessel temperature at 22.0 °C. The supply vessel plays the role of high-pressure compressor in this study. By opening and changing the EXV degree of opening, the mass flow rate of refrigerant through the circuit can be varied. However, in order to ensure that the R744 in the condenser is completely condensed and no remaining gas exists at the condenser outlet, only if the refrigerant temperature at the outlet was obviously below 22.0 °C, the test was proceeded.

On this way, for three values of R744 mass flow rate (0.0934 kg/s, 0.0998 kg/s, and 0.1060 kg/s) which correspond to three pressure differences of 70, 80, and 90 kPa through the differential pressure flow meter, the transient behavior of refrigerant temperature at the inlet and the outlet of the

## Experimental evaluation of transient heat transfer performance of an automotive condenser designed for R744 refrigerant

designed condenser is shown in Figs. 4 and 5, respectively, and the outlet of the designed condenser is shown in Figs. 4 and 5, respectively.

As it is shown in Fig. 4, the inlet temperature experiences a sudden drop and rise and finally, it is stabilized on approximately 22.0 °C. This is due to the fact that by the sudden opening of the EXV, an instantaneous pressure loss (i.e., a relative vacuum) through the condenser will be created which leads to a pressure drop, and consequently, the observed temperature drop at the inlet. However, a bit after, the regulator placed after the supply vessel releases the refrigerant toward the condenser which forms the second transient step, which is a rising of pressure and temperature. For higher mass flow rates, the amplitude of this drop and rise will be larger. This is because of the fact that for higher mass flow rates the EXV is promptly open more, and therefore the resulted sudden pressure drop (and as a result, temperature drop) will be more due to the more drainage of initial R744 from the condenser. On the other hand, the response of the regulator will be more obvious, which in turns resulted in a larger temperature rising. After about 30 s,

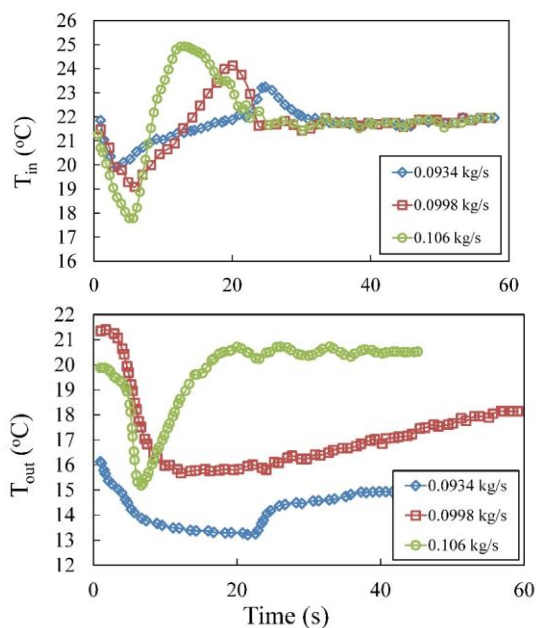

Figure 4: The transient behavior of R744 temperature at the (left) inlet and (right) outlet of the condenser for three different refrigerant mass flow rates.

the temperature will be stabilized on the desired temperature of 22.0 °C, for all three values of R744 mass flow rate.

As shown in Figure 4, the stabilized temperature at the condenser outlet is dissimilar for three experiments performed with three different R744 mass flow rates. More specifically, for larger mass flow rates the stabilized temperature at the condenser outlet will be larger; this is consistent with our general sense that for more refrigerant passing through the condenser, the degree of refrigerant subcooling will be less. Before the temperature becomes stabilized, the temperature transient behavior is completely different in the three cases. Generally, for the smallest mass flow rate, the least variation of temperature can be observed, while for the largest mass flow rate, the most variation of the temperature can be observed.

Overall, this investigation demonstrates that sufficient degree of refrigerant subcooling can be achieved for about 0.1 kg/s refrigerant mass flow rate (corresponding to 10-15 kW heat rejection rate) which indicates the sufficient performance of the designed and manufactured condenser. Based on the stabilized temperature of refrigerant and air in these three experiments, the effectiveness (the ratio of practical heat transfer rate to the maximum heat transfer rate) is calculated and reported in Table 2.

Table 2: Calculated effectiveness for the three experiments conducted to investigate the role of R744 mass flow rate.

Mass flow rate (kg/s)	0.0934	0.0998	0.106
Effectiveness	0.6852	0.7246	0.6726

### 5.2. Effects of air velocity through the condenser

In the second group of experiments, the refrigerant mass flow rate was fixed at 0.08645 kg/s, corresponding to 60 kPa pressure difference through the flowmeter.

Besides, the inlet pressure of the R744 refrigerant was fixed on 60 bar via controlling the supply vessel temperature at 22.0 °C. By turning on the tunnel fan and changing the frequency of the fan's electro motor, the wind velocity through the tunnel, and consequently, through the condenser can be altered. On this way, for three values of air velocity through the condenser (5.00 m/s, 6.25 m/s, and 7.50 m/s) the transient behavior of air temperature before and after the designed condenser placed in the wind tunnel is shown in Fig 5.

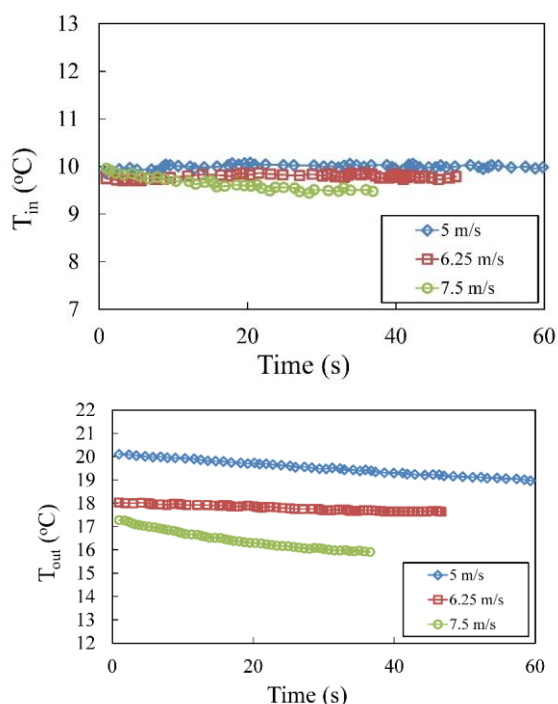

Figure 5: The transient behavior of air temperature (up) before and (down) after the condenser for three different values of air velocity through the condenser.

As shown in the figure, the air temperature after the condenser is dissimilar for three experiments performed with three different wind velocities. More specifically, for higher velocity of air through the condenser the stabilized temperature after the condenser will be lower; this is consistent with our general sense that for more rate of air passing through the condenser, the warming degree of air (due to absorbing heat from the refrigerant) will be less. In this figure, no significant transient behavior of the air temperature can be observed after the condenser. The results of this section

demonstrate that the heat transfer performance of the designed condenser is also appropriate at the air side. Based on the stabilized temperature of refrigerant and air in these three experiments, the effectiveness is calculated and reported in Table 3.

Table 3: Calculated effectiveness for the three experiments conducted to investigate the role of air velocity.

Mass flow rate (kg/s)	0.0934	0.0998	0.1060
Effectiveness	0.7007	0.5820	0.4978

## 6. Conclusion

Two groups of transient tests for different operating conditions in terms of wind velocity and R744 mass flow rate were performed and the refrigerant temperatures at the inlet and the outlet of the condenser as well as the air temperatures before and after the condenser heat exchanger are logged. In all experiments, the temperature of the supply vessel is controlled to be stabilized at 22.0 °C.

In the first group of experiments, the air velocity on the center line of wind tunnel was fixed at 5 m/s. By opening and changing the EXV degree of opening, the mass flow rate of refrigerant through the circuit can be altered. In these experiments, the inlet temperature experiences a sudden drop and rise and finally, it is stabilized on approximately 22.0 °C. This is due to an instantaneous pressure loss (i.e., relative vacuum) through the condenser, just after opening of EXV. Additionally, for higher mass flow rates, the amplitude of this drop and rise will be larger. At the condenser outlet, for the smallest mass flow rate, the least variation of temperature can be observed, while for the largest mass flow rate, the most variation of the temperature can be observed. For larger mass flow rates, the stabilized temperature will be larger.

In the second group of experiments, the refrigerant mass flow rate was fixed at 0.08645 kg/s, corresponding to 60 kPa pressure difference through the flowmeter. By turning on the tunnel fan and changing the frequency of the fan's electro motor, the wind

## Experimental evaluation of transient heat transfer performance of an automotive condenser designed for R744 refrigerant

velocity through the tunnel, and subsequently, through the condenser can be varied. Here, the air velocity does not have a significant effect on the upstream air temperature. For higher velocity of air through the condenser, the stabilized temperature after the condenser will be lower. Overall, this investigation demonstrates the sufficient performance of the designed and manufactured automotive condenser based on R744 refrigerant. Although the effectiveness of the condenser in the tests was about 0.6, the performance can be upgraded via inserting porous materials in the copper tubes of condenser.

### REFERENCES

- [1] Sukri MF, Musa MN, Senawi MY, Nasution H. 2015. Achieving a better energy-efficient automotive air-conditioning system: a review of potential technologies and strategies for vapor compression refrigeration cycle. *Energy Efficiency*, Vol. 8, No. 6, pp. 1201-1229. doi:10.1007/s12053-015-9389-4.
- [2] Diani A, Rossetto L. 2018. Experimental analysis of refrigerants flow boiling inside small sized microfin tubes. *Heat and Mass Transfer*, Vol. 54, No. 8, pp. 2315-2329. doi:10.1007/s00231-017-2111-7.
- [3] Toninelli P, Bortolin S, Azzolin M, Del Col D. 2019. Effects of geometry and fluid properties during condensation in minichannels: experiments and simulations. *Heat and Mass Transfer*, Vol. 55, No. 1, pp. 41-57. doi:10.1007/s00231-017-2180-7.
- [4] Punia SS, Singh J. 2015. An experimental study of the flow of LPG as refrigerant inside an adiabatic helical coiled capillary tube in vapour compression refrigeration system. *Heat and Mass Transfer*, Vol. 51, No. 11, pp. 1571-1577. doi:10.1007/s00231-015-1523-5.
- [5] Roy R, Mandal BK. 2019. Energetic and exergetic performance comparison of cascade refrigeration system using R170-R161 and R41-R404A as refrigerant pairs. *Heat and Mass Transfer*, Vol. 55, No. 3, pp. 723-731. doi:10.1007/s00231-018-2455-7.
- [6] Yi W-B, Choi K-H, Yoon J-I, Son C-H, Ha S-J, Jeon M-J. 2019. Exergy characteristics of R404A indirect refrigeration system using CO<sub>2</sub> as a secondary refrigerant. *Heat and Mass Transfer*, Vol. 55, No. 4, pp. 1133-1142. doi:10.1007/s00231-018-2497-x.
- [7] Ahmadpour MM, Akhavan-Behabadi MA, Sajadi B, Salehi-Kohestani A. 2020. Experimental study of R600a/oil/MWCNT nano-refrigerant condensing flow inside micro-fin tubes. *Heat and Mass Transfer*, Vol. 56, No. 3, pp. 749-757. doi:10.1007/s00231-019-02739-2.
- [8] Longo GA, Righetti G, Zilio C. 2019. Heat-transfer assessment of the low GWP substitutes for traditional HFC refrigerants. *International Journal of Heat and Mass Transfer*, Vol. 139, pp. 31-38. doi:10.1016/j.ijheatmasstransfer.2019.04.144.
- [9] Sandler S, Zajackowski B, Krolicki Z. 2018. Review on flow boiling of refrigerants R236fa and R245fa in mini and micro channels. *International Journal of Heat and Mass Transfer*, Vol. 126, pp. 591-617. doi:10.1016/j.ijheatmasstransfer.2018.05.048.
- [10] Lin L, Kedzierski MA. 2019. Review of low-GWP refrigerant pool boiling heat transfer on enhanced surfaces. *International Journal of Heat and Mass Transfer*, Vol. 131, pp. 1279-1303. doi:10.1016/j.ijheatmasstransfer.2018.11.142.
- [11] Yang C-Y, Nalbandian H. 2018. Condensation heat transfer and pressure drop of refrigerants HFO-1234yf and HFC-134a in



- small circular tube. *International Journal of Heat and Mass Transfer*, Vol. 127, pp. 218-227. doi:10.1016/j.ijheatmasstransfer.2018.07.093.
- [12] Li M, Dang C, Hihara E. 2013. Flow boiling heat transfer of HFO1234yf and HFC32 refrigerant mixtures in a smooth horizontal tube: Part II. Prediction method. *International Journal of Heat and Mass Transfer*, Vol. 64, pp. 591-608. doi: 10.1016/j.ijheatmasstransfer.2013.04.047.
- [13] Kuczynski W, Bohdal T, Meyer JP, Denis A. 2019. A regressive model for dynamic instabilities during the condensation of R404A and R507 refrigerants. *International Journal of Heat and Mass Transfer*, Vol. 141, pp. 1025-1035. doi:10.1016/j.ijheatmasstransfer.2019.06.095.
- [14] Abas N, Kalair AR, Khan N, Haider A, Saleem Z, Saleem MS. 2018. Natural and synthetic refrigerants, global warming: A review. *Renewable and Sustainable Energy Reviews*, Vol. 90, pp. 557-569. doi:10.1016/j.rser.2018.03.099.
- [15] Pitarch M, Navarro-Peris E, Gonzalez J, Corberan JM. 2016. Analysis and optimisation of different two-stage transcritical carbon dioxide cycles for heating applications. *International Journal of Refrigeration*, Vol. 70, pp. 235-242. doi: 10.1016/j.ijrefrig.2015.08.013.
- [16] Aprea C, Greco A, Maiorino A. 2013. The substitution of R134a with R744: An exergetic analysis based on experimental data. *International journal of refrigeration*, Vol. 36, No. 8, pp. 2148-2159. doi: 10.1016/j.ijrefrig.2013.06.012.
- [17] Turgut MS, Turgut OE. 2019. Comparative investigation and multi objective design optimization of R744/R717, R744/R134a and R744/R1234yf cascade refrigeration systems. *Heat and Mass Transfer*, Vol. 55, No. 2, pp. 445-465. doi:10.1007/s00231-018-2435-y.
- [18] Ge YT, Tassou SA, Santosa ID, Tsamos K. 2014. Design Optimisation of CO2 Gas Cooler/Condenser in a Refrigeration System. *Energy Procedia*, Vol. 61, pp. 2311-2314. doi: 10.1016/j.egypro.2014.11.1191.
- [19] Ding T, Li Z. 2016. Research on convection heat transfer character of super critical carbon dioxide flows inside horizontal tube. *International Journal of Heat and Mass Transfer*, Vol. 92, pp. 665-674. doi: 10.1016/j.ijheatmasstransfer.2015.09.026.
- [20] Ding T, Wen H, Guang Z, Li Z. 2017. Boiling heat transfer characteristics of the R744 coolant in the evaporator of the separated heat pipe system. *International Journal of Heat and Mass Transfer*, Vol. 113, pp.12541264. doi:10.1016/j.ijheatmasstransfer.2017.05.122.
- [21] Jiang L, Liu J, Zhang L, Liu Q, Xu X. 2017. Characteristics of heat transfer for CO2 flow boiling at low temperature in micro-channel. *International Journal of Heat and Mass Transfer*, Vol. 108, pp. 2120-2129. doi: 10.1016/j.ijheatmasstransfer.2016.12.113.
- [22] Son C-H, Oh H-K. 2012. Experimental study of the condensation heat transfer characteristics of CO2 in a horizontal microfin tube with a diameter of 4.95 mm. *Heat and Mass Transfer*, Vol. 48, No. 11, pp. 1867-1879. doi:10.1007/s00231-012-1027-5.
- [23] Steven Brown J, Yana-Motta SF, Domanski PA. 2002. Comparative analysis of an automotive air conditioning systems operating with CO2 and R134a. *International Journal of refrigeration*, Vol. 25, No. 1, pp. 19-32. doi: 10.1016/S0140-7007(01)00011-1.
- [24] Tamura T, Yakumar Y, Nishiwaki F. 2005. Experimental study on automotive cooling and heating air conditioning system using CO2 as a refrigerant. *International Journal of Refrigeration*, Vol. 28, No. 8, pp. 13021307. doi:10.1016/j.ijrefrig.2005.09.010.